

## Descripción

1.1 Fabricante			PR INDUSTRIAL
Elevación			Eléctrico
1.3 Grupo tracción			Eléctrico
1.4 Conducción			Acompañante
1.5 Capacidad carga	Q	Kg	1400
1.6 Centro gravedad	c	mm	600
1.8 Distancia de la carga	x	mm	935
1.9 Distancia entre ejes	y	mm	1196

## Weights

2.1 Peso con batería		Kg	256
2.2 Carga sobre ejes con carga, atras		Kg	1047
2.2 Carga sobre ejes con carga, delante		Kg	609
2.3 Carga sobre ejes sin carga, delante		Kg	213
2.3 Carga sobre ejes sin carga, atras		Kg	43

## Bastidor/Ruedas

3.1 Tyres: front wheels			GOMA
3.1 Tyres: stabilizers wheels - front			POLY.C.
3.1 Ruedas traseras			POLY.C.
3.2 Dimensiones ruedas delanteras - Ancha		mm	76
3.2 Dimensiones ruedas delanteras - Diametro		mm	250
3.3 Dimensiones ruedas traseras - Diametro		mm	82
3.3 Dimensiones ruedas traseras - Ancha		mm	80
3.4 Dimensiones Ruedas Laterales (Ø)		mm	100
3.4 Dimensiones Ruedas Laterales (ancho)		mm	40
3.5 Dimensiones ruedas traseras - Q.ty (X=motriz)		nr	2
3.5 Dimensiones ruedas delanteras - Q.ty (X=motriz)		nr	1x
3.6 Vía delantera	b10	mm	530
3.7 Vía trasera	b11	mm	375

## Dimensions

4.4 Elevación		h3 mm	115
4.9 Altura del timón max		h14 mm	1238
4.9 Height of tiller in drive position min		h14 mm	725
4.15 Altura horquillas bajadas		h13 mm	85
4.19 Longitud total		l1 mm	1560
4.20 Longitud de timón a horquillas		l2 mm	410
4.21 Ancho total		b1 mm	720
4.22 Dimensiones horquillas		s mm	55
4.22 Dimensiones horquillas		e mm	150
4.22 Dimensiones horquillas		l mm	1150
4.25 Ancho horquillas		b5 mm	525
4.32 Altura libre inferior, con carga, al centro entre ejes		m2 mm	30
4.34 Pasillo de trabajo para palet 800x1200 longit.		Ast mm	1810
4.35 Radio de giro		Wa mm	1345

### Performances

5.1 Travel speed laden	Km/h	6
5.1 Travel speed unladen	Km/h	6
5.10 Freno De Servicio		REVERSE CURRENT BRAKING

### Electric motors

6.6 Energy consumption according to VDI cycle	kWh/h	0.28
8.4 Sound level at driver's ear	dB(A)	59

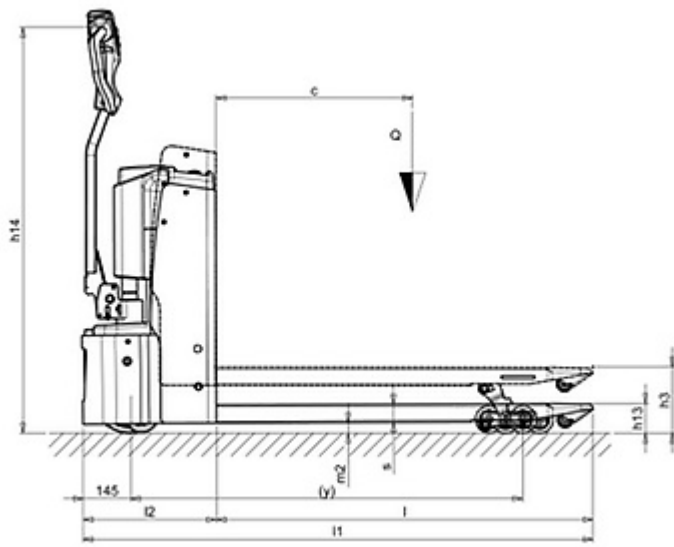
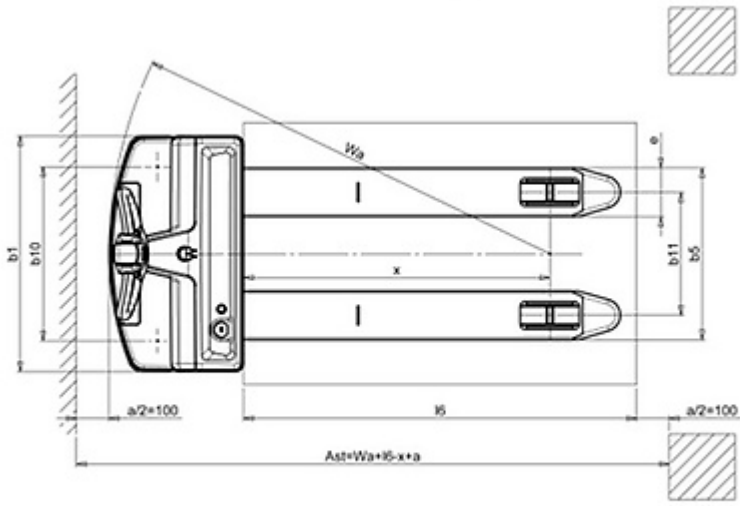

The information is aligned with the Data file at the time of download. Printed on 02/04/2020 (ID 9023)

©2019 | PR INDUSTRIAL s.r.l. | All rights reserved | Image shown may not reflect actual package. Specifications subject to change without notice

